

SharkBite® EvoPEX™ Ball Valve

DESCRIPTION

SharkBite EvoPEX ball valves are for use in residential or commercial systems and approved for potable water and glycol (up to 100% mix) in hot and cold domestic water systems as well as radiant heating systems. SharkBite EvoPEX ball valves are intended to be installed with SharkBite PEX pipe as a holistic system.

FEATURES AND BENEFITS

Instant push-to-connect ends for quick installation, immediate testing, and ease of use:
ID pipe seal, permanent connection, visual indicator to confirm connection, no tools, solder, clamps, rings, unions, or glue required.

Full Port Ball Valve:
Allows water to flow freely through valve



TECHNICAL DATA

Performance:

Pressure @ Temperature Ratings

80 psi @ 200°F

100 psi @ 180°F

250 psi @ 73.4°F

SharkBite Materials:

Item	Material
1 – Body Adapter	DZR LF Brass
2 – Seat	PTFE
3 – Stem O-rings	EPDM
4 – Stem	Brass
5 – Ball	DZR LF Brass
6 – Body	DZR LF Brass

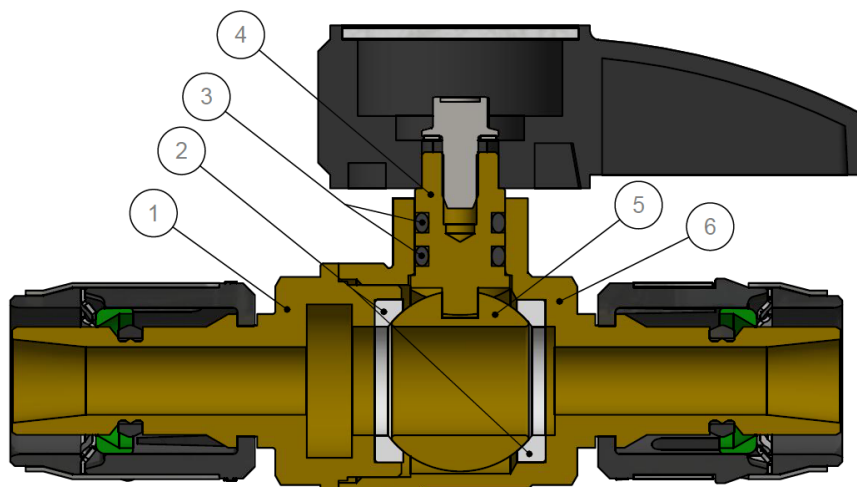

CERTIFICATIONS

SharkBite® EvoPEX™ ball valves 1/2", 3/4" and 1":

Certified to NSF/ANSI 359.

Listed to NSF/ANSI 359, NSF/ANSI 61, NSF 372, by IAPMO.

UPC, IPC, and NPC of Canada compliant

Patent pending

SPECIFICATION

SharkBite EvoPEX ball valves shall be installed on SharkBite PEX complying with ASTM F876 or CSA B137.5. The fittings shall be made of DZR LF Brass and be compliant with NSF/ANSI 359. The fittings shall be used in a potable water or radiant heating/cooling system not to exceed 80 psi @ 200°F, 100 psi @ 180°F, or 250 psi @ 73.4°F



SharkBite® EvoPEX™ Ball Valve

PART	DESCRIPTION	A	B	WEIGHT
K22222	BALL VALVE 1/2" X 1/2"	3.633	2.044	0.356
K22185	BALL VALVE 3/4" X 3/4"	3.886	2.047	0.438
K22223	BALL VALVE 1" X 1"	4.524	2.391	0.775

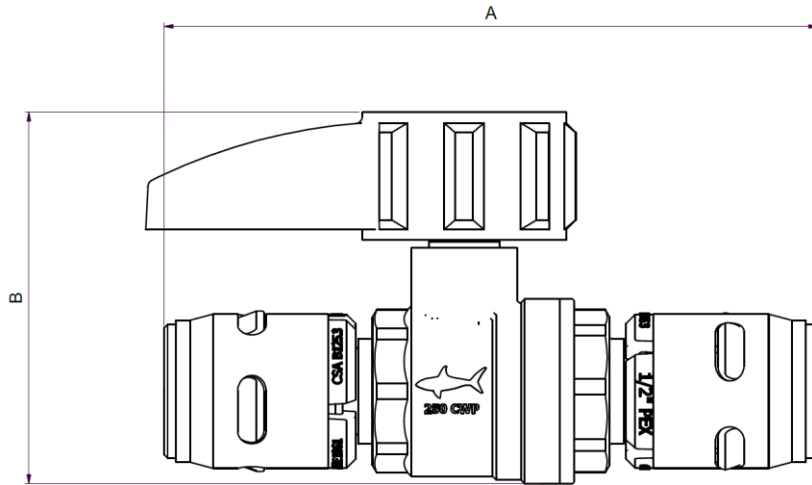

www.evo-plex.com · 2727 Paces Ferry Road · Building 2 · Suite 1800 · Atlanta · Georgia 30339 · USA

US Contact: 1-877-700-4242 · customerservice@sharkbite.com · Canadian Contact: 1-888-820-0120 · canadasales@rwc.com

