

Product Submittal	
Name	
Date	
Architect/Owner	
Contractor	
Tag	
Notes	

## EB25 Plus Pressure Regulator Specification Sheet

### Description

The EB25 Plus brings state-of-the-art water control technology to pressure regulators. The accurate flow control and pressure regulation of the EB25 Plus eliminates the need for costly multi-valve installation such as high-low valves installed in parallel to meet varying flow requirements or multi-valves installed in series to reduce high inlet pressures to desired line pressure.

The EB25 Plus is a lead-free product designed to service commercial and institutional water installations that experience wide variation in water demand or for applications where there are high inlet pressures. The valve is available in 2-1/2", 3", and 4" sizes, all with flanged connections. The valve is factory set at 55 psi.



### Features And Benefits

- **Service all the parts quicker and easier**  
Single piece cartridge can be removed with valve body remaining in place.
- **Regulate minimum to maximum flow effectively with one valve**  
Coaxial double spring design eliminates the need for high flow- low flow (1/3 – 2/3) valve arrangement with a single valve. EB25 Plus PRV saves cost on additional valve and associated accessories with savings on installation time and most importantly valuable space.
- **No add-ons or small parts, longer life and more reliable performance**  
Integral back-pass with the cartridge.
- **Meets the latest stringent international standards, quieter installation**  
Cutting edge design and production incorporates "micro-fingers" that dissipate noise due to water flow across the seat.
- **No more dummy valve necessary**  
Available with a blanking cap for "rough-in" installations.

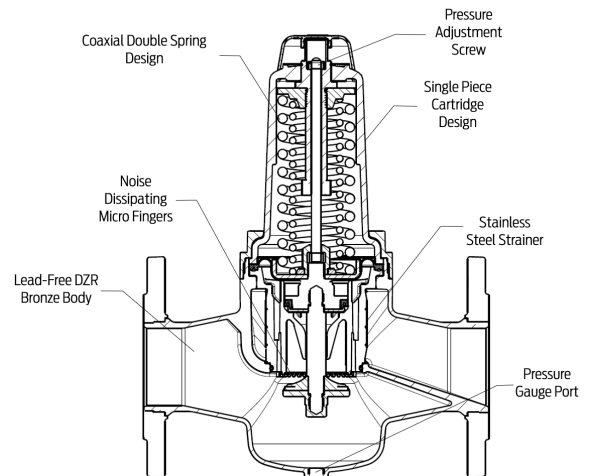

### Specification

A pressure regulating valve shall be installed to reduce high supplies of incoming water pressure. The valve shall have a single cartridge that can accommodate a high range of flow conditions. The valve shall be a Cash Acme EB25 Plus.

## Specification Data

### Performance:

Adj. outlet pressure range	30 psi – 85 psi
Factory set pressure	55 psi
Maximum inlet pressure	230 psi (1600 kPa)
Max operating temperature	149°F
Service	Potable Water Service

### Materials:

Body	Lead free dezincification resistant bronze
Strainer	Stainless steel integral strainer
Spring	Stainless steel spring
Seals & Diaphragm	High temperature rated aging resistant elastomer (EPDM)

## Available Connections

Model	Part #	Flange Inlet (DIN) x Outlet (DIN)
EB25 Plus	25958	2-1/2"
EB25 Plus	25859	3"
EB25 Plus	25860	4"

Flange Dimensions		
Size	Mounting Holes	Bolt Circle Dia. (mm)
2-1/2"	4	145
3"	8	160
4"	8	160

## Codes & Standards

The EB25 Plus is certified to ASSE 1003\*, CSA B356\*, NSF/ANSI 372, and NSF/ANSI/CAN 61 standards. The EB25 Plus is listed with CSA and IAPMO and meets all the requirements in National Plumbing Code of Canada, Uniform Plumbing Code, and the International Plumbing Code.

\* Not applicable to 4" sizes

## Dimensions

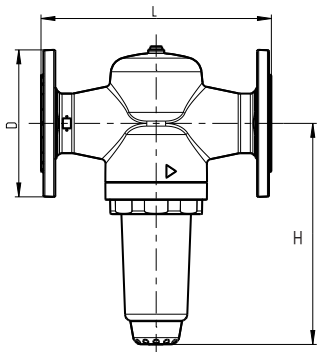

Part #	Size	L (mm)	H (mm)	D (mm)
25958	2-1/2"	290	278	67
25859	3"	310	278	80
25860	4"	350	278	100
26007	Replacement Cartridge works on all sizes.			

## Typical Installation

The Cash Acme EB25 Plus Pressure Regulator comes supplied with a pre-adjusted pressure set at the factory. The pressure can be easily adjusted in the field by use of a spanner.

The EB25 Plus Pressure Regulator can be mounted in any position – vertical, horizontal, upwards, inverted or any other desired orientation.

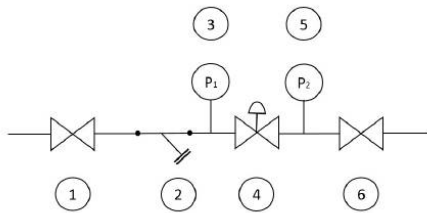

### Legend

1. Stop Valve (Ball, Butterfly, Gate, etc.)
2. Strainer (Optional EB25 Plus contains a built-in strainer)
3. Pressure Gauge 1
4. EB25 Plus PRV
5. Pressure Gauge 2
6. Stop Valve (Ball, Butterfly, Gate etc.)

## Flow Capacity (GPM)

